

# EXHIBIT 1: IDENTIFIED PROPERTIES

## MACLEAY RD SE AT CAPLINGER RD SE: PEDESTRIAN IMPROVEMENTS PN: 721514

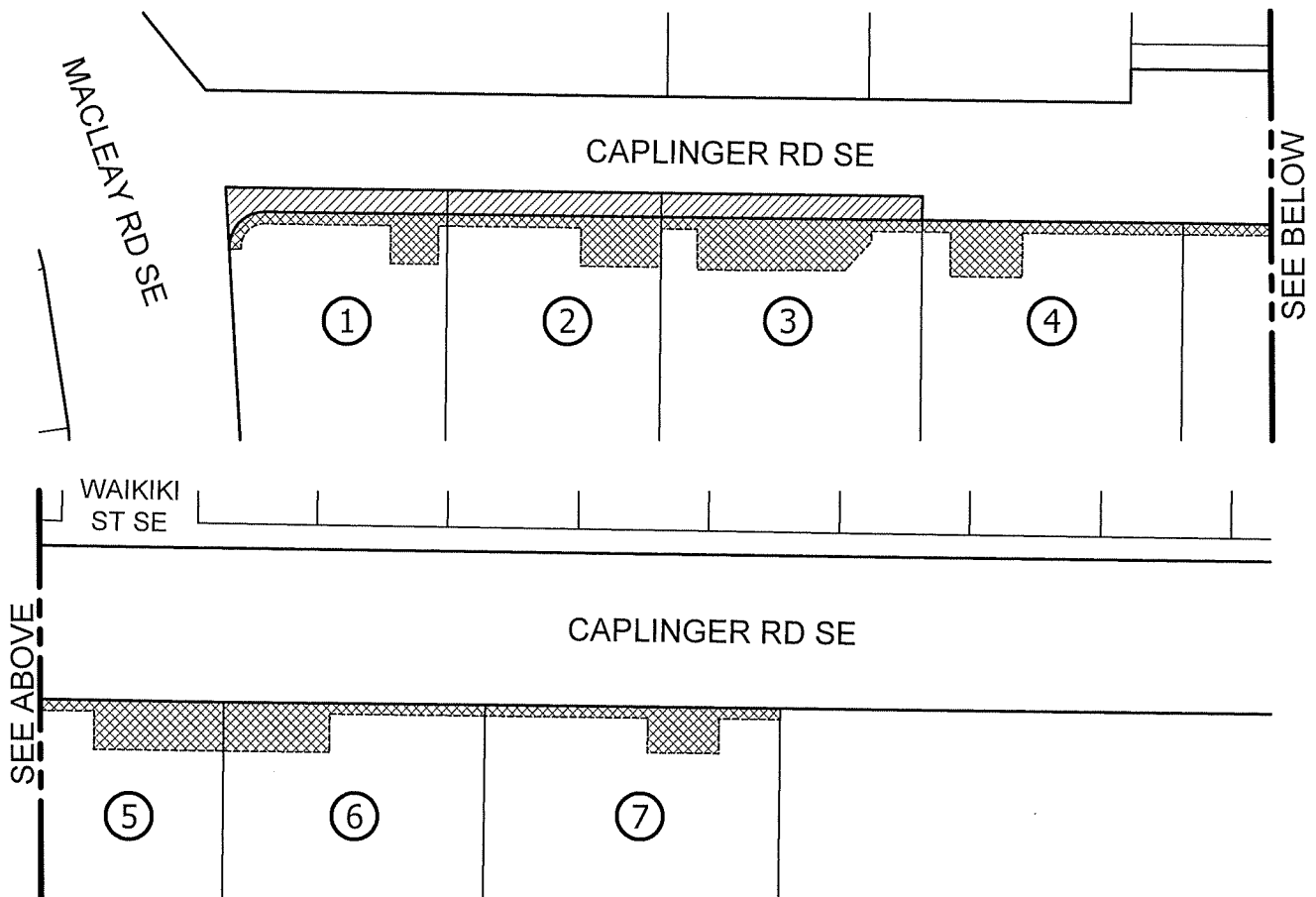

### LEGEND



RIGHT-OF-WAY  
ACQUISITION AREA



TEMPORARY CONSTRUCTION EASEMENT (TCE)  
ACQUISITION AREA



PROPERTY ID NUMBER

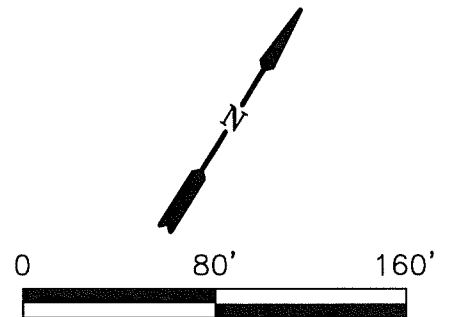

### Public Works Department

APWA ACCREDITED AGENCY

ENGINEERING DIVISION  
555 Liberty Street SE, Room 325  
Salem, OR 97301-3513  
Phone 503-588-6211  
www.cityofsalem.net

June 2023

# EXHIBIT 1: PROPERTY OWNERSHIP SUMMARY

## MACLEAY RD SE AT CAPLINGER RD SE: PEDESTRIAN IMPROVEMENTS PN: 721514

PROPERTY ACQUISITION SUMMARY						
CAPLINGER ROAD SE PROPERTY ACQUISITIONS						
PROJECT No.: 721514						
Property ID #	Owner Name and Address	Situs Address	Tax Map	Tax Lot	Acquisition Area Type	
					ROW	Temporary Construction Easement
1	Julie K Schultz	5010 CAPLINGER RD SE SALEM, OR, 97317	072W32D	1700	X	X
2	Indalecio Mota Cervantes & Maria I Cerda Torres	5030 CAPLINGER RD SE SALEM, OR, 97317	072W32D	1600	X	X
3	Toni L Lorusso	5090 CAPLINGER RD SE SALEM, OR, 97317	072W32D	1500	X	X
4	Laura Bayne Mcelroy	5110 CAPLINGER RD SE SALEM, OR, 97317	072W32D	1400		X
5	Theresa McCormick	5120 CAPLINGER RD SE SALEM, OR, 97317	072W32D	1300		X
6	Greenwood Creek Property LLC 8100 SW Laurelwood CT Portland, OR 97225	5130 CAPLINGER RD SE SALEM, OR, 97317	072W32D	1200		X
7	Jinxing Pan	5150 CAPLINGER RD SE SALEM, OR, 97317	072W32D	1100		X



**Public Works Department**

APWA ACCREDITED AGENCY

ENGINEERING DIVISION  
555 Liberty Street SE, Room 325  
Salem, OR 97301-3513  
Phone 503-588-6211  
www.cityofsalem.net

June 2023